

# Question Paper Code : 8301

B.Tech. (Semester-I) Examination, 2017

## ENGINEERING MATHEMATICS - I

[ AS-103 ]

[Time: 3 Hours]

[Total Marks: 70]

Note: This question paper contains three sections as follows.

### SECTION - A

1. Attempt any nine parts of the following: [1×9 = 9]

(a) Prove that matrix  $A = \frac{1}{\sqrt{2}} \begin{bmatrix} 1 & i \\ -i & -1 \end{bmatrix}$  is unitary.

(b) Find the Eigen values of  $9A^{-1} + A + 3I$  if  
 $A = \begin{bmatrix} 1 & 0 \\ 4 & 3 \end{bmatrix}$ .

(c) Find the  $n^{\text{th}}$  derivative of  $\cos^2 x$ .

(d) State Euler's theorem for homogeneous functions.

(e) Find the percentage error in measuring the area of a rectangle when error of 1% is made in measuring the length and breadth.

(f) If  $x = u(1+v)$ ,  $y = v(1+u)$ , then find  $\frac{\partial(x, y)}{\partial(u, v)}$ .

(g) Find  $\text{curl } \vec{r}$ .

(h) State Green's theorem.

(i) Compute  $\Gamma(-3/2)$ .

(j) Evaluate  $\int_1^2 \int_0^{x/2} dy dx$ .

### SECTION-B

**Note:** Attempt all the questions from this section.

2. Attempt any two parts of the following: [2×4=8]

(a) Find the rank of the following matrix by reducing it into normal form

$$A = \begin{bmatrix} 0 & 1 & -3 & -1 \\ 1 & 0 & 1 & 1 \\ 3 & 1 & 0 & 2 \\ 1 & 1 & -2 & 0 \end{bmatrix}$$

(b) Investigate for what values of  $\lambda$  and  $\mu$ , the system of equations  $x + y + z = 6$ ;  $x + 2y + 3z = 10$ ;  $x + 2y + \lambda z = \mu$  has (i) no solution, (ii) unique solution, (iii) infinite number of solutions.

8301/400

(2)

(c) Find the inverse of the following elementary transformations

$$\begin{bmatrix} 3 & -3 & 4 \\ 2 & -3 & 4 \\ 0 & -1 & 1 \end{bmatrix}$$

3. Attempt any two parts of the following: [2×4=8]

(a) If  $u = \tan^{-1} \frac{xy}{\sqrt{1+x^2+y^2}}$ , then prove that

$$\frac{\partial^2 u}{\partial x \partial y} = (1+x^2+y^2)^{-3/2}$$

(b) If  $w = z \log y + y \log z + xyz$ , where

$x = \sin t$ ,  $y = t^2 + 1$ ,  $z = \cos^{-1} t$ , find  $\frac{dw}{dt}$  at  $t = 0$

(c) Trace the curve  $y^2(a-x) = x^3$ .

4. Attempt any two parts of the following: [2×4=8]

(a) Obtain the Taylor's series expansion of maximum order for the following function in powers of  $(x-1)$  and  $(y+1)$

$$f(x, y) = 2x^2 - xy + y^2 + 3x - 4y + 1.$$

8301/400

(3)

[P.T.O.]



(b) If  $x = u(1-v)$  and  $y = uv$ , verify that

$$\frac{\partial(u,v)}{\partial(x,y)} \cdot \frac{\partial(x,y)}{\partial(u,v)} = 1.$$

(c) Find the percentage error in computing the parallel resistance  $r$  of two resistances  $r_1$  and  $r_2$  when  $r_1$  and  $r_2$  are both in error by +2% each.

5. Attempt any two parts of the following: [2×4=8]

(a) Find the directional derivative of

$\phi = xy + yz + zx$  in the direction of  $2\hat{i} + \hat{j} + \hat{k}$  at the point (1,1,2). Also find the maximum value of directional derivative.

(b) Prove that  $\text{Curl}(\phi\vec{V}) = \nabla\phi \times \vec{V} + \phi\text{Curl}\vec{V}$

(c) Prove that  $\nabla^2(r^m) = m(m+1)r^{m-2}$  and hence show that  $\nabla^2\left(\frac{1}{r}\right) = 0$ .

6. Attempt any two parts

(a) Express  $\int_0^1 x^m (1-x^n)^p dx$  in terms of Beta

function and hence evaluate  $\int_0^1 x^5 (1-x^3)^{10} dx$ .

(b) Evaluate the following integral by changing into polar coordinates

$$\int_0^a \int_0^a \frac{x}{x^2 + y^2} dy dx$$

(c) Evaluate  $\iiint x^2 yz dx dy dz$  throughout the volume bounded by the planes  $x = 0$ ,  $y = 0$ ,  $z = 0$  and the plane  $\frac{x}{a} + \frac{y}{b} + \frac{z}{c} = 1$

### SECTION-C

Note: Attempt any three questions from this section. (3×7=21)

7. Verify Cayley-Hamilton theorem for the following matrix and hence find  $A^{-1}$ ,  $A^{-2}$ .

$$A = \begin{bmatrix} -2 & 2 & 3 \\ 2 & 1 & -6 \\ -1 & -2 & 0 \end{bmatrix}$$

8. Find the  $n^{\text{th}}$  derivative at  $x=0$  for the function

$$y = \left[ \log(x + \sqrt{1+x^2}) \right]^2$$

9. Find the dimensions of a rectangular box of maximum capacity whose surface is given when box is open at the top.

10. Verify Stoke's theorem for  $\vec{F} = (x^2 + y^2)\vec{i} - 2xy\vec{j}$  taken around the rectangle bounded by  $x = \pm a, y = 0, y = b$ .

11. Change the order of integration in the following integral and hence evaluate it

$$I = \int_0^2 \int_{x^2/4}^{x-y} (x^2 + y^2) dx dy$$

---X---



# Question Paper Code: 8302

B.Tech. (Semester-I) Examination, 2017-18

## ENGINEERING PHYSICS-I

[ AS-101 ]

[Time: 3 Hours]

[Total Marks: 70]

**Note:** This question paper contains three sections as follows.

### SECTION-A

1. Attempt **any nine** parts of the following [9x1=9]
- (a) Write the postulates of special theory of relativity.
  - (b) Show that no particle can move with the velocity more than that of light.
  - (c) Mention the de-Broglie hypothesis of matter wave.
  - (d) Define group velocity and phase velocity. Also write the relation between them.
  - (e) What are the coherent sources of light ? Give two examples.

- (f) What are the retardation plates ? Write the expression for thickness of half wave plate and quarter wave plate.
- (g) Write the essentials of laser action.
- (h) Write the Rayleigh's criterion for the limit of resolution.
- (i) Define core, clad and jacket of optical fibers.
- (j) What is the basic principle of holography ?

### SECTION-B

2. Attempt **any two** parts of the following : [2x4=8]

- (a) Show that  $x^2 + y^2 + z^2 - c^2t^2$  is invariant under Lorentz transformation.
- (b) Establish Einstein's mass-energy relation. Give two physical examples of Einstein's mass-energy equivalence.
- (c) Find the speed of 0.1 MeV electrons according to the classical and relativistic mechanics.

3. Attempt **any two** parts of the following: [2x4=8]

- (a) State Heisenberg uncertainty principle. If the uncertainty in the location of a particle is equal

to its de Broglie wavelength, then find out the uncertainty in its velocity.

- (b) Write the Plank's hypothesis for radiation. Also obtain the Rayleigh-Jeans Law.
- (c) A particle of charge  $q$  and mass  $m$  is accelerated from rest through a potential difference  $V$ . Find its de Broglie wavelength. Calculate the wavelength ( $\lambda$ ), if the particle is an electron and  $V = 50$  Volt.

4. Attempt **any two** parts of the following : [2x4=8]

- (a) Write the condition of secondary maxima for a single slit and show that the intensities of the successive maxima are in the ratio  $1 : 1/22 : 1/61 : 1/121 \dots$
- (b) Why the center of Newton's ring is dark in case of thin air film ? What will happen if:
- (i) a little water is introduced between lens and plate
- (ii) a plane mirror is used instead of a glass plate.
- (c) A diffraction grating used at normal incidence gives a yellow line ( $\lambda = 6000 \text{ \AA}$ ) in a certain spectral order superimposed on a blue line



( $\lambda=4800 \text{ \AA}$ ) of next higher order. If the angle of diffraction is  $\sin^{-1}\left(\frac{3}{4}\right)$ , determine the grating element.

5. Attempt **any two** parts of the following : [2x4=8]

- (a) Describe construction and working of Nicol prism.
- (b) The indices of refraction of quartz for right handed and left handed circularly polarized light of wavelength  $7620 \text{ \AA}$  are  $1.53914$  and  $1.53920$  respectively. Calculate the rotation of the plane of polarization of the light in degrees produced by a plate  $0.5 \text{ mm}$  thick.
- (c) Mention the essential conditions for lasing action. With the help of suitable diagram, explain the principle, construction and working of Ruby laser.

6. Attempt **any two** parts of the following : [2x4=8]

- (a) An optical fiber has a NA of  $0.20$  and a cladding refractive index of  $1.59$ . Determine the acceptance angle for the fiber in water which has a refractive of  $1.33$ .

reconstruction of a hologram. List some important applications of holography.

- (c) Describe the Propagation Mechanism of optical signals through optical fiber with suitable ray diagram.

### SECTION-C

**Note:** Attempt **any three** questions from this section. [3x7=21]

7. (a) Obtain the relativistic form of Newton's second Law.
- (b) The mass of a moving electron is 2 times to its rest mass. Find its kinetic energy and momentum.
8. (a) What was the objective of Davisson-Germer experiment ? Discuss the results of this experiment.
- (b) Using Uncertainty principle show that electron cannot reside in the nucleus.
9. (a) Derive the expression for the resolving power of grating.
- (b) In Newton's ring experiment the diameter of the  $4^{\text{th}}$  and  $12^{\text{th}}$  dark rings are  $0.4$  and  $0.7 \text{ cm}$  respectively. Find the diameter of  $20^{\text{th}}$  dark ring.



10. (a) What is polarized light ? How will you produce and detect plane, elliptically and circularly polarized light ?
- (b) With the help of suitable diagram, explain the principle, construction and working of He-Ne laser.
11. (a) Explain the following terms:
- (i) Numerical aperture
  - (ii) Acceptance angle
  - (iii) Acceptance cone
- (b) A step index fiber has core refractive index 1.566, cladding refractive index 1.56. If operating wavelength of the rays is  $0.84 \mu\text{m}$ , calculate the cut-off parameter and the number of modes, which are supported by this fiber. The diameter of core =  $50 \mu\text{m}$ .

---- x ----



# Question Paper Code : 8303

B.Tech. (Semester-I) Examination, 2017

## ENGINEERING CHEMISTRY

(AS-102)

[Time: 3 Hours]

[Total Marks: 70]

**Note:** This question paper contains three sections as follows.

### SECTION -A

1. Attempt **any nine** parts of the following: [9x1=09]

- (i) Give reaction for removal of temporary hardness in a water sample by boiling.
- (ii) Predict the number of  $^1\text{H}$  NMR signals and splitting in  $(\text{CH}_3)_2\text{CHCH}_2\text{Cl}$ .
- (iii) Name the sugar moiety present in RNA and DNA.
- (iv) Write the structure of EDTA.
- (v) On the basis of MO theory explain why  $\text{O}_2$  is paramagnetic.

- (vi) Name the monomers for the preparation of Buna-N.
- (vii) Why GCV is greater than NCV?
- (viii) Define degree of freedom.
- (ix) What will happen if a Zn rod is vertically half submerged under water?
- (x) What is the fingerprint region in IR spectroscopy?

### SECTION – B

**Note:** Attempt **all** the questions from this section.

2. Attempt any **two** parts of the following: [2 x 4=8]
- (a) What are stoichiometric and non-stoichiometric defects? Explain Frenkel and Schottky defects found in solids.
  - (b) Draw the molecular orbital diagrams of  $N_2^-$  and calculate its bond order. Will  $N_2^-$  be paramagnetic or diamagnetic?
  - (c) Discuss the structure and applications of Fullerenes.

3. Attempt **any two** parts of the following: [2 x 4=8]
- (a) Differentiate between Chain Growth and Step Growth polymerization process.
  - (b) What are organometallic compounds? How will  $CH_3CH_2MgBr$  react with  $HCHO$ ,  $CH_3CHO$ , and  $(CH_3)_2CO$ ?
  - (c) Explain vulcanization of rubber. Give the preparation and uses of Neoprene rubber.

4. Attempt **any two** parts of the following: [2 x 4=8]
- (a) What are Solid Lubricants? Explain the mechanism of lubrication by solid lubricants.
  - (b) Explain the setting and hardening of cement with relevant chemical reactions involved.
  - (c) The emf of a cell measured by means of a hydrogen electrode against a saturated calomel electrode at 298 K is 0.4188 V. If the pressure of the  $H_2$  (g) was maintained at 1 atm, calculate the pH of the unknown solution, given potential of reference calomel electrode is 0.2415 V.



5. Attempt **any two** parts of the following: [2 x 4=8]

- (a) How are scales formed in the boilers? How can scale formation be prevented in boilers?
- (b) A sample of water contains following impurities (in mg/L):  $\text{Mg}(\text{HCO}_3)_2=73$ ;  $\text{CaSO}_4 = 68$ ;  $\text{MgSO}_4= 12$ ;  $\text{MgCl}_2=95$ ;  $\text{Ca}(\text{HCO}_3)_2= 81$ ;  $\text{NaCl}= 4.8$ . Calculate the amount of lime (95% pure) and soda (90% pure) required for softening 20,000 litres of this water sample.
- (c) Discuss the application of phase rule to water, vapour and ice system.

6. Attempt **any two** parts of the following: [2 x 4=8]

- (a) On burning 0.3g of a solid fuel in a bomb calorimeter, the temperature of 3500g of water increased from  $26.5^\circ$  to  $29.2^\circ$  C. Water equivalent of calorimeter and latent heat of steam are 385.0g and 587.0 cal/g respectively. If the fuel contains 0.7% hydrogen, calculate its gross and net calorific value.
- (b) What are chromophores and auxochromes? A diene (molecular formula  $\text{C}_4\text{H}_6$ ) shows an intense peak at  $\lambda_{\text{max}}$  217 nm while another diene (molecular formula  $\text{C}_5\text{H}_8$ ) shows an

intense peak at  $\lambda_{\text{max}}$  175 nm in their UV spectra. Giving proper explanation assign the structures to the two dienes.

- (c) For  $\text{XY}_2$  bent molecule show various types of stretching and bending vibrations in IR spectroscopy.

### SECTION – C

**Note :** Attempt **any three** questions from this section: [3x7=21]

7. (a) What are liquid crystals? Describe different types of liquid crystals.
- (b) Write a brief note on nano materials and its applications.
8. (a) What are Aramids? Give the preparation and uses of Kevlar and Nomex.
- (b) What are conducting polymers? Discuss their applications.
9. (a) How can corrosion be minimized by proper design?
- (b) Differentiate between anodic and cathodic metallic coatings.

10. Explain the zeolite process for softening of water. The hardness of 10,000 litres of water sample was removed by passing it through a zeolite softener. The zeolite softener then required 200 litres of sodium chloride solution containing 150 gm/ litre of NaCl for regeneration. Find the hardness of water sample in ppm.
11. Why is TMS used as an internal standard in NMR spectroscopy? Two isomeric compounds A and B have molecular formula  $C_{10}H_{14}$ . The  $^1H$  NMR spectra of these isomers gave following data:

Isomer A:  $\delta$  1.30 (9H, s);  $\delta$  7.28 (5H, s)

Isomer B:  $\delta$  0.88 (6H, d);  $\delta$  1.86 (1H, m);  $\delta$  2.45 (2H, d);  $\delta$  7.12 (5H, s)

--- x ---



# Question Paper Code : 8304

B.Tech. (Semester-I) Examination, 2017

**BASIC ELECTRICAL ENGINEERING**

(EE-101)

[Time: 3 Hours]

[Total Marks: 70]

**Note :** This question paper contains three sections as follows.

## SECTION-A

1. Attempt **any Nine** parts of the following:- [9x1=9]
- (a) Define active elements.
  - (b) Define bilateral elements.
  - (c) Define Form factor.
  - (d) Define RMS value.
  - (e) Define power factor.
  - (f) What is the condition of maximum power transfer?
  - (g) In star connection give the relation between phase voltage and line voltage.

- (h) List different types of measuring instruments.
- (i) Draw B-H curve.
- (j) Write emf equation of single phase transformer.

**SECTION-B**

**Note :** Attempt all the questions from this section.

2. Attempt any two parts of the following: [2x4=8]

- (a) Derive the expression for star to delta transformation.
- (b) Find the current in 15 ohm resistor (Fig. 1) by Thevenin's theorem :



Fig. 1

- (c) Find current in 5 ohm resistor (Fig.2) by source transformation method :



Fig. 2

3. Attempt any two parts of the following:- [2x4=8]

- (a) The armature of a 4-Pole DC machine has 200 conductors and runs at 600 rpm. The emf generated in open circuit is 220V. Find the useful flux per pole when armature is :

(i) Lap Connected.

(ii) Wave Connected.

- (b) Draw the construction diagram of a DC machine and describe its parts in brief.

- (c) Explain the principle of operation of synchronous generator.



Attempt any two parts of the following:- [2x4=8]

- (a) Three impedances  $(6 + j5)$ ,  $(8-j6)$  and  $(8 + j10)$  are connected in parallel. Calculate the current in each branch when the total current is 20 A.
- (b) Derive phase and line voltage relation in delta connection.
- (c) Explain resonance in parallel circuits.

5. Attempt any two parts of the following:- [2x4=8]

- (a) Prove that the sum of two wattmeter readings give the total three phase real power.
- (b) Draw and explain the principle of operation of a dynamometer type instrument.
- (c) Explain the construction and principle of operation of repulsion type moving iron instrument.

6. Attempt any two parts of the following:- [2x4=8]

- (a) A 40 KVA single phase transformer has core loss of 450W and full load copper loss of 850W. If the power factor of the load is 0.8, calculate efficiency at :

8304/300

(4)

(i) Full load

(ii) Half load.

- (b) Describe the analogies and differences between the electric and magnetic circuits.
- (c) Derive the equivalent circuit of a single phase transformer.

### SECTION-C

Note : Attempt any three questions from this section. [3x7=21]

7. Explain bandwidth and quality factor.
8. A varying current with a periodic waveform flows through an 8 ohm resistor in accordance with the following pattern:
  - (a) For the first 0.04 second, it is constant at 6 A.
  - (b) For the next 0.02 second, it is zero.
  - (c) For the remaining 0.04 second, it is constant at 2 A in the reverse direction.

Determine (i) the mean value (ii) the r.m.s value (iii) the heat dissipated in the resistor in 5 minutes.

8304/300

(5)

[P.T.O.]

9. (a) Calculate the line current of a three phase alternator delivering 5 MW at 33 KV and working at 0.8 power factor.
- (b) Draw single line diagram of the power system.
10. A magnetic core in the form of a closed ring has a mean length of 20 cm and a cross section of  $1 \text{ cm}^2$ . The relative permeability of iron is 2400. What direct current will be needed in a coil of 2000 turns uniformly wound round the ring to create a flux of 0.2 m Wb in the iron?
11. Explain the principle of operation of a three-phase Induction motor.

--- x ---



# Question Paper Code : 8305

B.Tech. (Semester-I) Examination, 2017

## ELEMENTS OF MECHANICAL ENGINEERING

(ME-101)

[Time: 3 Hours]

[Total Marks: 70]

**Note:** This question paper contains three sections as follows:

### SECTION - A

1. Attempt **any nine** parts of the following: [9x1=9]
- Define Hooke's law.
  - What do you mean by composite and alloy?
  - Define the principle of transmissibility of force.
  - State Varignon's theorem of moments.
  - Define perfect and imperfect truss.
  - Write the expression for maximum bending moment of simply supported beam (length  $L$ ) carrying uniformly distributed load of  $w$  per unit length.

- g) Write the expression for work done and heat transfer for adiabatic expansion from initial condition  $(P_1, V_1)$  to final condition  $(P_2, V_2)$ .
- h) Differentiate between intensive and extensive properties with example.
- i) Differentiate between refrigerator and heat pump.
- j) Write the value of pressure and temperature of steam at critical point.

### SECTION - B

**Note:** Attempt **all** the questions from this section.

2. Attempt **any two** parts of the following : [2x4=8]

- a) Eight bolts are to be selected for fixing the cover plate of a cylinder subjected to a maximum load of 980.175 kN. If the design stress for the bolt material is  $315 \text{ N/mm}^2$ , what is the diameter of each bolt?
- b) A heavy uniform rod of length 'L', cross sectional area 'A', and material density ' $\rho$ ' is hung vertically with its top end rigidly fixed. How is the total elongation of the bar under its own weight expressed?

- c) Define following mechanical properties of materials :

Ductility, Hardness, Toughness and Creep

3. Attempt **any two** parts of the following. [2x4=8]

- a) From a rectangular sheet of metal ABCD in which  $AB=60$  and  $BC=40$  cm, a circle of 4 cm radius is removed from the centre. Find the centroid of remaining portion.
- b) Tension in cable BC is 725-N, determine the resultant of the three forces exerted at point B of beam AB as shown in fig 1.

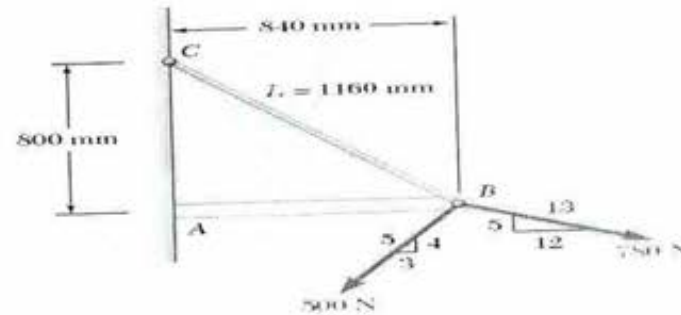

Fig. 1

- c) Two identical rollers, each of mass 100kg are supported by inclined plane and vertical wall as shown



in fig 2. Find the reaction support at A, B, C and D. Assume surfaces are smooth.

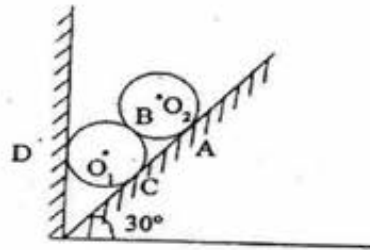

Fig 2

4. Attempt **any two** parts of the following. [2X4=8]

- Draw the shear force and bending moment diagram for the beam of length  $L$  having fixed support at both the end and a moment  $M$  in clockwise direction acting at the centre of the beam.
- Define truss. How the Trusses are classified? Explain method of section to find out the forces in member in truss.
- Derive the relation between loading intensity, shear force and bending moment.

5. Attempt **any two** parts of the following : [2X4=8]

- State the Zeroth law of thermodynamics. In a thermoelectric thermometer for  $t$  °C temperature, the emf is given as:  $E = 0.003t - 5 \times 10^{-7}t^2 + 0.5 \times 10^{-3}$ , volts. Thermometer is having reference junction at ice point and is calibrated at ice point and steam points. What temperature shall be shown by the thermometer for a substance at 40 °C.
- A vacuum gauge mounted on a condenser reads 0.55 mm Hg. What is the absolute pressure in the condenser in kPa when the atmospheric pressure is 101.3 kPa?
- 6 kg/s of air enters a nozzle at 1 MPa and 500 K and leaves at 200 kPa and 27 °C. The heat loss from the nozzle is estimated to be 90 kW. Find the velocity and area at the exit of nozzle. Neglect approach velocity. Take  $R = 0.287$  J/kg K, Ratio of specific heats = 1.4.

6. Attempt **any two** parts of the following. [2X4=8]

- Draw Rankine cycle on P-v and T-s diagram. In a steam turbine installation running on simple rankine cycle steam leaves the boiler at 10

MPa and  $700^{\circ}\text{C}$  and leaves the turbine at  $5\text{ kPa}$ . For the  $100\text{ MW}$  output of the plant find heat added in the boiler in  $\text{kW}$  and efficiency of the cycle. Neglect pump work.

- b) A cyclic heat engine operates between a source temperature of  $800^{\circ}\text{C}$  and a sink temperature of  $30^{\circ}\text{C}$ . What is the least rate of heat rejection per  $\text{kW}$  net output of the engine?
- c) Distinguish between SI and CI engines with proper explanation.

### SECTION - C

**Note :** Attempt any three questions from this section.  $[3 \times 7 = 21]$

7. Draw shear force and bending moment diagram of overhanging beam shown in fig 3. Also find maximum moment and point of contra flexure.

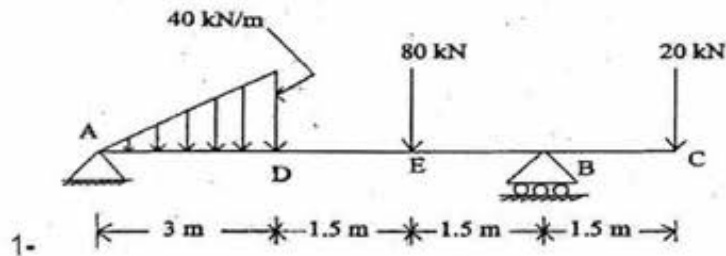

Fig 3

8. Determine the forces in all member of truss in given fig 4.

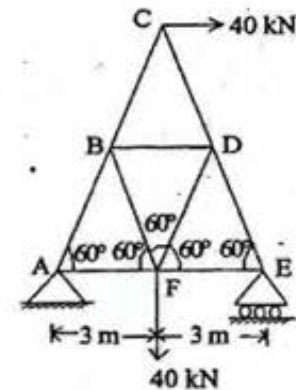

Fig 4

9. Forces are acting as shown in fig 5. Find the magnitude, direction and position of the resultant force.

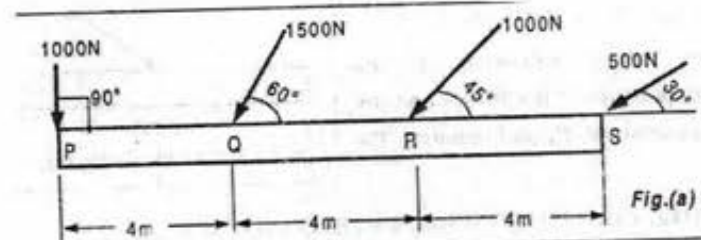



Fig 5

10. Differentiate work and heat transfer.  $3 \text{ m}^3$  of air is contained in rigid insulated vessel at  $50 \text{ }^\circ\text{C}$  and  $150 \text{ kPa}$ . A wax candle is burning in the centre of a vessel. After one hour the final pressure in the vessel is  $900 \text{ kPa}$ . Find the change in internal energy of air and mass of wax combusted in one hour. Assume calorific value of wax as  $8 \text{ MJ/kg}$  and neglect the change in volume of air due to wax combustion. Also find the change in internal energy and work done by air in vessel.
11. Define the critical point and dryness fraction of steam. A pressure cooker contains  $5 \text{ kg}$  of dry and saturated steam at  $4 \text{ bar}$ . Calculate the amount of heat that must be rejected so that the steam becomes wet with  $0.8$  dryness fraction. Find pressure and temperature of steam after heat rejection.

--- x ---

# Question Paper Code : 8306

B.Tech. (Semester-I) Examination, 2017

PROFESSIONAL COMMUNICATION

(AS-104)

[Time: 3 Hours]

[Total Marks: 70]

**Note:** This question paper contains three sections as follows.

## SECTION –A

1. Attempt **any nine** parts of the following: [9x1=9]
- a) Distinguish between technical communication and general communication.
  - b) Differentiate between intra-personal and inter-personal barriers to communication.
  - c) Distinguish definite article from indefinite article by citing two examples for each one.
  - d) Describe the requisites of a good sentence in brief.
  - e) What do you mean by 'you' attitude in business communication?



- f) Distinguish between claim and adjustment letters.
- g) Explain the basic elements of speech delivery.
- h) Distinguish between inductive and deductive order of paragraph development.
- i) Distinguish humanistic approach from scientific approach to human activity apropos M.E. Prior.
- j) Who is the mother of the sciences according to A.J. Bahm?

### SECTION -B

**Note:** Attempt **all** the questions from this section.

2. Attempt **any two** parts of the following: [2x4=8]
- a) Explain the features of technical communication in brief.
  - b) Prove that language is a carrier of cultural heritage.
  - c) Describe the flow of communication usually followed in professional organizations.

3. Attempt **any two** parts of the following: [2x4=8]

- a) Write the meaning of **any four** of the following homophones and use them in statements:
  - i) Ensure, Insure
  - ii) Adapt, Adept
  - iii) Tamper, Temper
  - iv) Draught, Drought
  - v) Emigrant, Immigrant
- b) Describe various methods to bring about unity in a technical paragraph. Illustrate.
- c) Correct **any four** of the following sentences:
  - i) My uncle has three daughter-in-laws.
  - ii) None but fools has believed it.
  - iii) She has the roundest face.
  - iv) Delhi is London of India.
  - v) Time makes worst enemies friends.



4. Attempt **any two** parts of the following: [2x4=8]

- a) Define technical report. Signify its importance for engineers.
- b) What is technical proposal? Explain its use for professionals.
- c) Describe the qualities of a good negotiator precisely.

5. Attempt **any two** parts of the following: [2x4=8]

- a) Distinguish between extempore and impromptu modes of speech delivery.
- b) Describe the features of body language. How could bad gesture spoil the outcome of any oral presentation?
- c) Distinguish between rhythm and intonation as paralinguistic features of voicedynamics.

6. Attempt **any two** parts of the following: [2x4=8]

- a) Critically evaluate the language of literature and that of science as enunciated by A. Huxley in his essay.

- b) What is the specific approach of Barry Commoner regarding the human survival in the wake of scientific and technological advancements.
- c) Explain the role of philosophy for all the scientific discoveries as propounded by A. J. Bahm in his essay.

### Section –C

**Note:** Attempt **any three** questions from this section: [3x7=21]

7. Specify the causes of Organizational barriers to internal communication in any organization.
8. Distinguish between Gerund and Infinitives by citing two examples for each one.
9. Draft a claim letter pertaining to the damage of five sets of computer systems out of twenty as per the purchase order issued to the firm based at Delhi. Invent necessary details.
10. Define attitude. Suggest different methods to transform negative attitude into positive one.
11. Prove that man is not the master but part of nature apropos the views of J. Bronowski in his essay.

--- X ---



# Question Paper Code: 8307

B.Tech. (Semester-I) Examination, 2017

## BASIC ELECTRONICS ENGINEERING

(EC-101)

[Time: 3 Hours]

[Total Marks: 70]

Note: This question paper contains three sections as follows.

### SECTION-A

1. Attempt any nine parts of the following: [9x1=9]
- (a) A transistor has an emitter current of 10mA and a collector current of 9.95mA. Calculate its base current.
  - (b) What is p-type material and n-type material? Explain.
  - (c) What are the PIVs for full wave center tapped transformer and bridge rectifier respectively?
  - (d) What is clipping circuit?
  - (e) Define current gain  $\alpha$  &  $\beta$ .

- (f) Why FET is known as unipolar device?
- (g) List the ideal characteristic of the Op-Amp.
- (h) A 200 watt carrier is modulated to a depth of 80%. Calculate the total power of the modulated wave.
- (i) What is the application of digital multimeter?
- (j) Define Frequency Modulation.

### SECTION -B

**Note:** Attempt all the questions from this section.

2. Attempt **any two** parts of the following: [2x4=8]
- (a) What is static resistance of the diode? How will you find dynamic resistance of the diode?
  - (b) Draw the neat diagram of a full wave bridge rectifier circuit. Explain its working in detail, clearly making direction of flow of currents for positive and negative cycles.
  - (c) Draw the circuit diagram of full wave voltage doubler circuit and explain the working operation.

3. Attempt **any two** parts of the following: [2x4=8]
- (a) Draw the circuit diagram of a BJT emitter bias and derive the expression for Quotient Point. Write its advantage over BJT fixed bias circuit.
  - (b) With a neat sketch, explain the working of a p-channel depletion mode MOSFET.
  - (c) Sketch a voltage divider bias circuit using an npn transistor. Show all voltage polarities and current directions. Derive the approximate equations for  $V_B$ ,  $I_E$ ,  $I_C$  and  $V_{CE}$ .

4. Attempt **any two** parts of the following: [2x4=8]
- (a) Draw the structure of a JFET and explain its principle of operation with the help of neat diagram along its V-I characteristics. Define pinch-off voltage and mark it on the characteristic.
  - (b) Draw and explain the circuit diagram for Integrator operation using op-amp.
  - (c) Find output voltage  $V_O$  for the op-amp circuit shown in fig.1. Assume ideal op-amp.



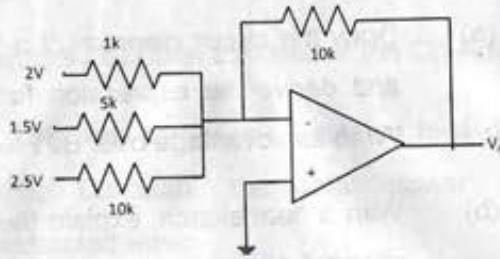

Fig. 1

5. Attempt **any two** parts of the following: [2x4=8]

- Draw the block diagram of the digital multimeter and explain its working operation.
- Explain the basic principle of digital voltmeter with the help of suitable block diagram.
- Explain how frequency and phase can be measured using CRO.

6. Attempt **any two** parts of the following: [2x4=8]

- With the help of block diagram explain the communication system.
- What is the need of the modulation? Explain.
- Explain the demodulation technique of AM wave with the help of suitable diagram.

**Note:** Attempt **any three** questions from this section. [3x7=21]

7. Determine  $V_L$ ,  $I_L$ ,  $I_Z$  and  $I_R$  for the following fig.2

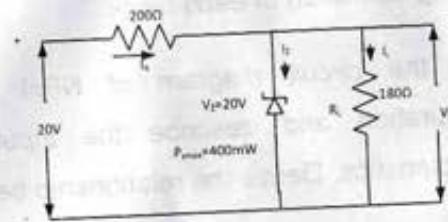

Fig. 2

8. Determine  $I_C$ ,  $V_E$ ,  $V_B$ ,  $V_C$ , and  $I_B$  for the following circuit shown in fig. 3.

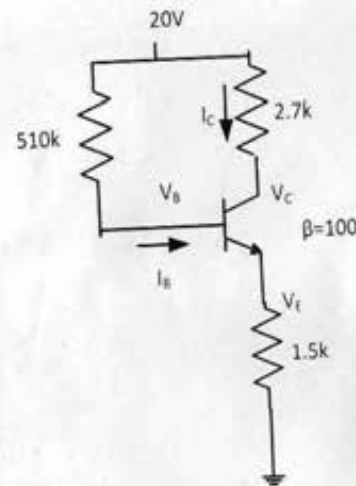

Fig. 3

9. Explain the following terms in respect to op-amp (i) input off-set voltage (ii) output off-set voltage (iii) input biased current (iv) slew rate (v) CMRR
10. Draw the block diagram of CRO and explain the working operation of each block.
11. Draw the circuit diagram of NPN transistor CE configuration and describe the input and output characteristics. Derive the relationship between  $\alpha$  &  $\beta$ .

---X---





# Question Paper Code: 8308

B.Tech. (Semester-I) Examination, 2017

## COMPUTER SYSTEM AND PROGRAMMING IN C (CS-101)

[Time: 3 Hours]

[Total Marks: 70]

**Note:** This question paper contains three sections as follows.

### SECTION-A

1. Attempt **any Nine** Parts of the following : [1x9=9]
  - a. Differentiate between Compiler & Interpreter.
  - b. Differentiate between Assembly Language & Machine Language.
  - c. Give the examples of Arithmetic, Relation & Boolean operators used in C.
  - d. Differentiate between signed & unsigned integer variable used in C.
  - e. Give the syntax of switch statement used in C Programming language.

- f. Write the usage of break statement used in C.
- g. Suppose an array of 10 integers is defined what is the memory requirement of this array.
- h. Write use of Union used in C.
- i. Define macros used in C
- j. Define pointers used in C.

### SECTION-B

**Note:** Attempt **all** the questions from this section.

2. Attempt **any Two** parts of the following [2x4=8]
- a. Draw the flow chart for finding the greatest among the three given numbers.
  - b. Draw the block diagram of a Digital Computer & explain the working of each part in brief.
  - c. Convert the following hexadecimal number into binary number.

$$(ABFC0987)_{16} = (----?-----)_2$$

3. Attempt **any Two** parts of the following: [2x4=8]
- a. Explain with example the use of bitwise operators used in C.
  - b. Give the syntax & semantic of Input & Output statements used in C.
  - c. Write program in C to know that whether the given Integer is Prime or not.
4. Attempt **any Two** parts of the following: [2x4=8]
- a. Explain with example how to replace a 'for' loop with a 'while' loop in C
  - b. Write a recursive function in C for finding the factorial of a given integer.
  - c. Write function in C for finding the sum of all digits of a given number.
5. Attempt **any Two** parts of the following: [2x4=8]
- a. Write function in C for finding the sum of the diagonal elements of a given square matrix.
  - b. Write a function in C for finding the sum of n integers stored in 1- D array.
  - c. Explain with example the use of enumerated type data in C programming language.



6. Attempt **any Two** parts of the following [2x4=8]

a. Explain the difference between following declarations in C programming Language:

i) int a[10]

ii) int \*a

iii) int \*a[10]

iv) int (\*a)[10]

b. Explain the different file access modes used in C programming Language.

c. Write a function in C for swapping of two numbers with the help of Pointers.

### SECTION C

**Note:** Attempt **any Three** questions from this section:

[3x7=21]

7. Write a program in C for converting a given integer into its binary equivalent.

8. Explain with example different types of storage classes used in C programming Language.

9. Write a program in C which accepts a number and display it in words. ( Eg. 456-→Four Five Six)

10. Write program in C for finding the transpose of a given matrix.

11. Write the syntax & use of the following C functions :

i) fseek( )

ii) ftell( )

iii) rewind( )

--- x ---